

Features

- $\varnothing 500 \mu\text{m}$ active area
- High QE for $\lambda = 850\text{-}1064 \text{ nm}$
- Low noise
- Low slope multiplication curve

Description

Circular active area APD chip with IR enhanced sensitivity. Very low dark current due to guard ring diode. Metal can type hermetic TO5i package with clear glass window.

Application

- Pulsed 1064 nm laser detection
- Laser range finding
- Fluorescence detection

RoHS

2011/65/EU

Absolute maximum ratings

Symbol	Parameter	Min	Max	Unit
T_{STG}	Storage temp	-55	125	$^{\circ}\text{C}$
T_{OP}	Operating temp	-40*	100	$^{\circ}\text{C}$
M_{max}	Gain ($I_{\text{PD}} = 1 \text{ nA}$)	1000		
I_{PEAK}	Peak DC current		0.25	mA

Spectral response (M = 100; 23 $^{\circ}\text{C}$)

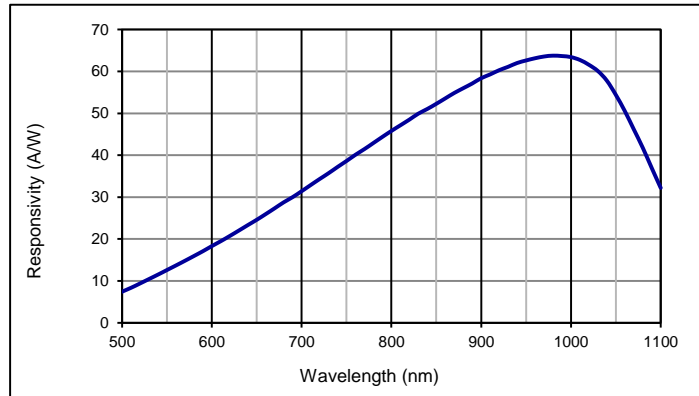

Schematic

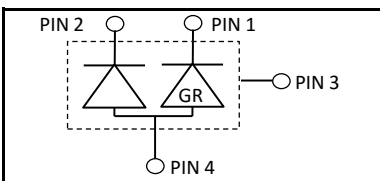

Electro-optical characteristics @ 23 $^{\circ}\text{C}$

Symbol	Characteristic	Test Condition	Min	Typ	Max	Unit
	Active area			$\varnothing 500$		μm
	Active area			0.2		mm^2
I_{D}	Dark current	M = 100		1.5	10	nA
C	Capacitance	M = 100		0.5		pF
	Responsivity	M = 100; $\lambda = 905 \text{ nm}$		59		A/W
	Responsivity	M = 100; $\lambda = 1064 \text{ nm}$		49		A/W
t_{R}	Rise time	M = 100; $\lambda = 1064 \text{ nm}$; $R_{\text{L}} = 50 \Omega$		4		ns
t_{R}	Cut-off frequency	-3dB		90		MHz
V_{BR}	Breakdown voltage	$I_{\text{R}} = 2 \mu\text{A}$	220	300	600	V
	Temperature coefficient			3.3		V/K

Quantum efficiency (23 °C)

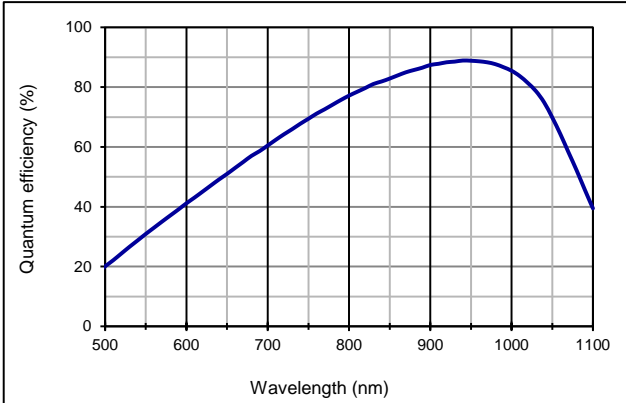

Capacitance as fct of reverse bias (23 °C)

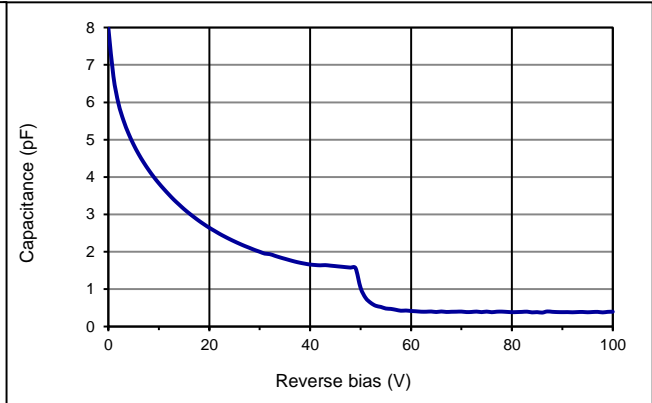

Multiplication as fct of reverse bias

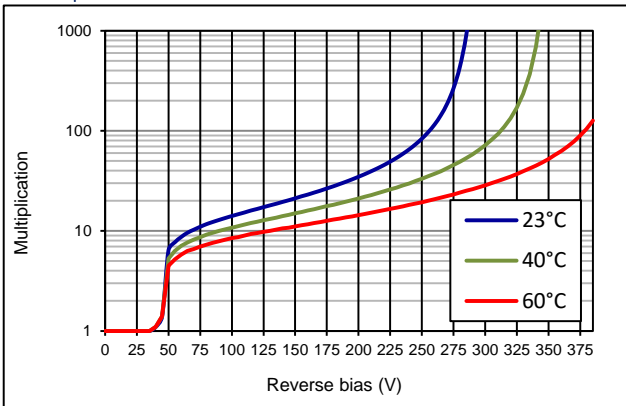

Dark current as fct of reverse bias

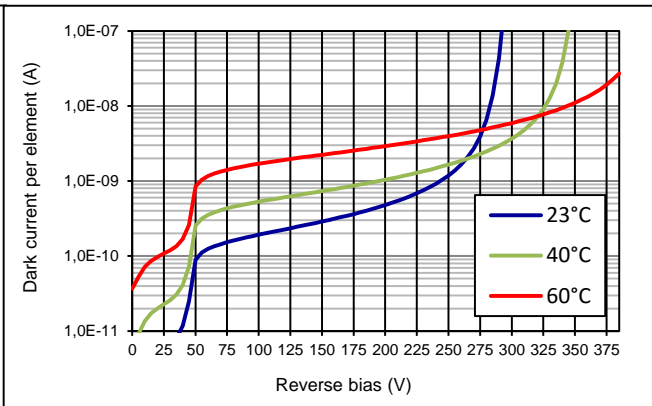

Application hints:

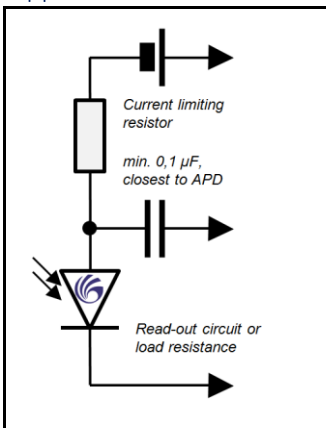

- Current should be limited by a protecting resistor or current limiting - IC inside the power supply
- Guard ring should be connected to ground
- For low light level applications blocking of ambient light should be used
- For high gain applications bias voltage should be temperature compensated
- Please consider basic ESD protection while handling
- Use low noise read-out - IC
- For further questions please refer to document "Instructions for handling and processing" and application notes for APDs and APD-Arrays

Package dimension:

Small quantities: Foam pad, boxed (12 cm x 16.5 cm)